

CRM 200S-RF RGB is a tri-element omni-directional boundary layer through table condenser microphone, with a built-in mechanism that allows users to retract the microphone fully into the table. The microphone is fitted with a RGB electronic capacitive touch sensitive switch designed to be used for remote switching. Available in black Nextel (CRM 200S-RF RGB) or Satin Nickel (CRM 200SN-RF RGB).

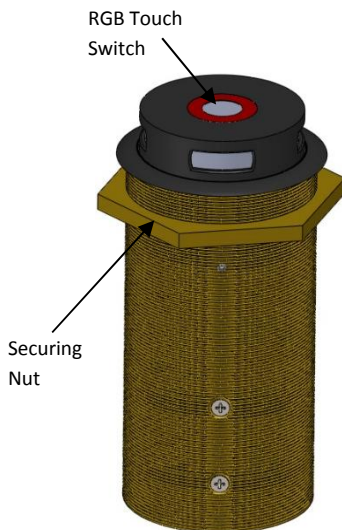

#### Switch Features

- RGB electronic capacitive touch switch facilitating click/pop free switching.
- Programmable via a DSP to display up to seven colour combinations and operate in PTT, PTM or Latching modes.
- Works only in conjunction with supplied TS-C1 touch switch controller that accepts 6 way colour coded ribbon cable from RGB LEDs, a 2 way phoenix connector for connection to the reed switch and TS-OUT for connection to a DSP via a CAT-5 Ethernet cable.

#### Microphone features

- Omni-directional polar pattern.
- Balanced output that is immune to RF artifacts.
- Fitted with a magnetic reed switch that prevents unwanted feedback while retracted; contact status available via TS-C1.
- Power requirements 9-48V phantom power.
- Cable 2m 2 core + screen.

Note: Reed switch status shall be used by DSP for muting.

#### Installation guide

- 1) Drill a 58mm (2.25") hole through the table (Fig A).
- 2) Remove the nut and fit the microphone through the hole (Fig B).
- 3) Replace nut and tighten to the underside of the table (Fig C).
- 4) Microphone connections: Red Phase +, White Phase – and screen Ground.

Note: microphone screen and TS-C1 ground must have a common ground connection.

- 5) TS-C1's TS-OUT wiring for connection to DSP:

Pin number	Function
1	Switch (Low indicating contacts closed on RS-IN )
2	Red LED (pulled low to illuminate)
3	Ground
4	+12V DC
5	Touch Switch Activated
6	Green LED (pulled low to illuminate)
7	Blue LED (pulled low to illuminate)
8	No connection

- 6) Grey 2 core (red and blue wires) connected to TS-C1's RS-IN.
- 7) Using p-clamps provided fix cables to the underside of the table ensuring there is sufficient slack in the cable loom for the mic to operate (Fig D).
- 8) Affix TS-C1 under table.

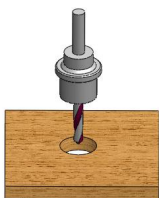

Fig A



Fig B

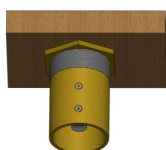

Fig C

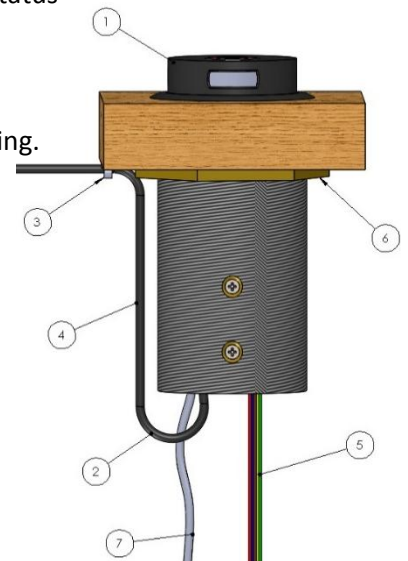

Fig D, key:

- 1) Head in raised position.
- 2) Loop cable allowing at least 25mm (1") out of the bottom of the CRM.
- 3) Fit supplied P-clamp using self-tap screws.
- 4) Black audio cable.
- 5) 6 way colour coded RGB switch wires.
- 6) Securing nut.
- 7) Grey switch cable red and blue cores.